

# MODEL 700

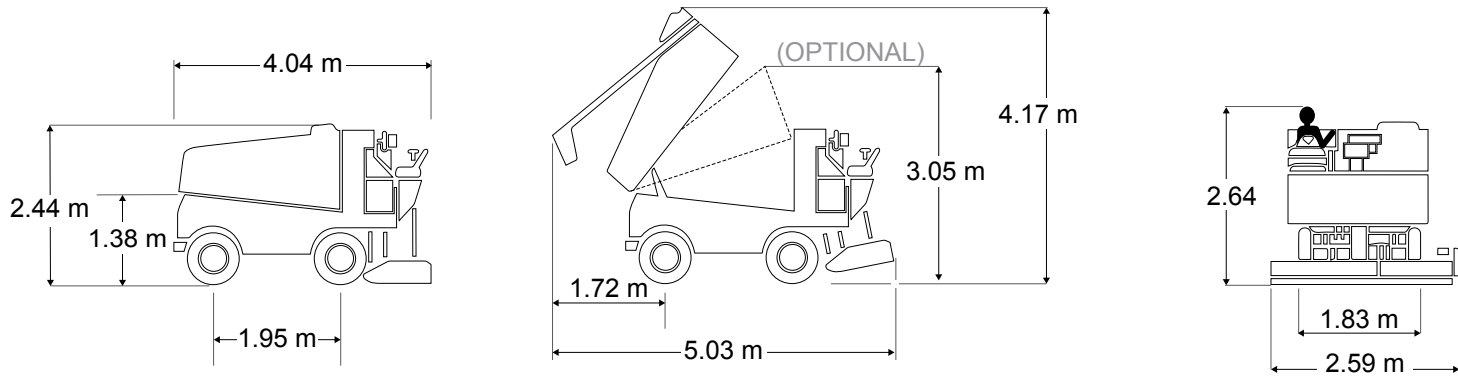

## CAPACITIES

Snow Tank		
Actual Volume	3.54 m <sup>3</sup>	125 cu. ft.
Compacted	4.53 m <sup>3</sup>	160 cu. ft.
Excess Water	662 L	175 gal.
Water		
Ice Making	1514 L	400 gal.
Wash Water	416 L	110 gal.
Total	1930 L	510 gal.
Hydraulic Oil	125 L	33 gal.

## POWERTRAIN

Four-Wheel Drive	
Engine	GM® 4.3 L Six Cylinder Engine 75 kW / 100 HP at 2800 RPM
Transmission	Continuously variable hydrostatic pump and motor are axial-piston type.
Hydraulics	Double pump powers the vertical and horizontal augers. Hydraulic down pressure for optimal resurfacing results.
Axles	Rugged Dana Spicer® Model 70 Axles
Brakes	Full Hydrodynamic Braking

## DIMENSIONS

Overall	L	W	H	L	W	H
Snow Tank Down	4.04 m	2.59 m	2.44 m	159 in.	102 in.	96 in.
Snow Tank Up	5.03 m	2.59 m	4.17 m	198 in.	102 in.	164 in.
Shaving Blade	L	W	H	L	W	H
	243.8 cm	12.7 cm	1.27 cm	96 in.	5 in.	0.5 in.
Clearance						
Minimum Operator Height Clearance			264.2 cm			104 in.
Snow Pit Clearance			1.38 m			54.5 in.
Conveyor System						
Horizontal Auger Diameter			25.4 cm			10 in.
Vertical Auger Diameter			25.4 cm			10 in.
Manueverability						
Wheelbase			1.96 m			77 in.
Wheel Track			1.83 m			72 in.
Turning Radius at Conditioner			6.1 m			20 ft.
Weight						
Empty			4273 kg			9420 lb
with Water			6214 kg			13700 lb

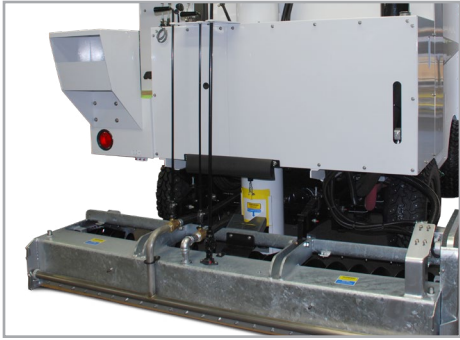

### Galvanized Conditioner

Durable galvanized steel provides a scratch-free finish with protection from rust.

\*optional equipment



### Zamboni Power Brush™

Wider brush path reaches higher on the dasher board kick plate for superior cleaning power.

\*optional equipment

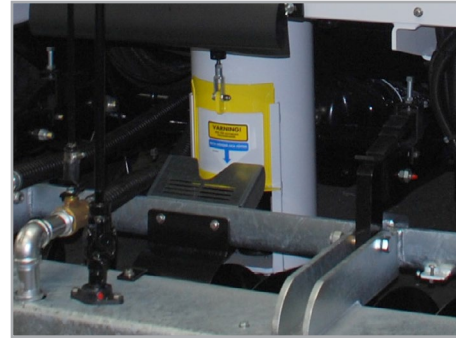

### Automatic Snow Breaker

Eliminates the need for manual control of the snow breaker by the machine operator.

\*optional equipment



## STANDARD FEATURES

- 2 Year Warranty
- 400 Micron Wash Water Deep Filter Bag
- Chassis: Strong All Welded Steel Tubing
- Chrome Wheels
- Conditioner Safety Guards
- Digital Training and Reference Materials
- Engine: EPA and CARB Certified
- Familiar Automobile-Style Foot Controls
- Four-Wheel Drive
- Fuel Options: Gasoline, Propane
- Full Hydrodynamic Braking
- Galvanized Steel Ice Making Water Tank
- Guide Wheel
- Headlights and Tail Light (for Off Ice Travel)
- High Quality 9 and 10 Micron Filters
- High Speed Vertical Auger
- Hydraulic Oil Level Sight Gauge
- Load Sensing Engine Governor
- Multi-Function Display

- On-Dash Diagnostics
- Parking Brake
- Power Steering
- Replaceable Poly Conditioner Side Plates
- Rugged Dana Spicer® Axles
- Snow Tank Safety Stand
- Spare Tire and Wheel
- Stainless Steel Hardware
- Steering Wheel Spinner Knob
- Touch-Up Paint Kit
- Tungsten Carbide Studded Tires
- Under Seat Storage
- Wide Spectrum of Premium Automotive Paint Colors

## OPTIONS

- Automatic Snow Breaker
- Back Up Alarm
- Cab Enclosure
- Conditioner: Galvanized
- Electric Water Level Gauge
- Hydraulic Oil Cooler Kit
- IceCaps® Wheel Advertising System
- Low Fuel Light
- Snow Melting Kit
- Snow Tank Dump Height Restriction
- Snow Tank Light
- Tire Wash System
- Wash Water to Ice Making Water Transfer System