

MODEL 552^{AC} ELECTRIC

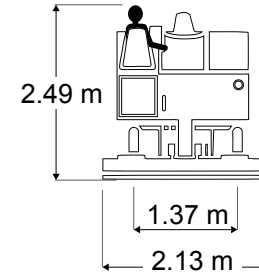
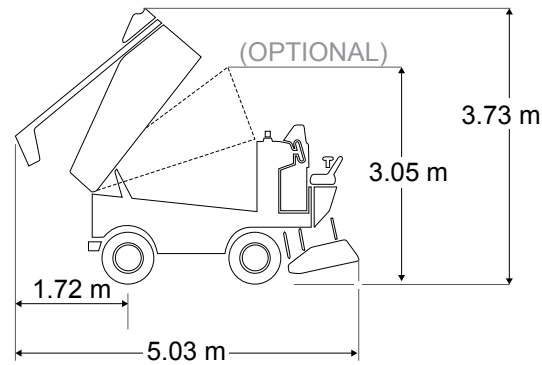
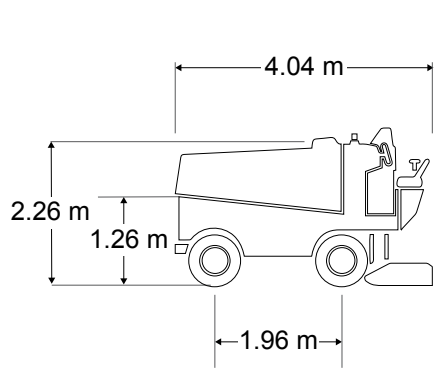

CAPACITIES

Snow Tank

Actual Volume	2.83 m ³	100 cu. ft.
Compacted	3.54 m ³	125 cu. ft.

Water

Ice Making	738 L	195 gal.
Wash Water	310 L	82 gal.
Total	1048 L	277 gal.

Hydraulic Oil	60.6 L	16 gal.
----------------------	--------	---------

POWERTRAIN

Four-Wheel Drive

Motors

Electric Hydraulic Pump Motor	8.2 kW	11 HP
Electric Traction Motor	17.9 kW	24 HP

Battery Standard	80V, 510 Ah (40.8 kWh)	Lead Acid (LA)
-------------------------	------------------------	----------------

Axles

Front	2903 kg	6400 lb
Rear	2903 kg	6400 lb

DIMENSIONS

Overall

	L	W	H	L	W	H
Snow Tank Down	4.04 m	2.13 m	2.26 m	159 in.	84 in.	89 in.
Snow Tank Up	5.03 m	2.13 m	3.73 m	198 in.	84 in.	147 in.

Shaving Blade

	L	W	H	L	W	H
195.6 cm 77 in. Blade	195.6 cm	12.7 cm	1.27 cm	77 in.	5 in.	0.5 in.

Clearance

Minimum Operator Height Clearance	248.9 cm	98 in.
Snow Pit Clearance	125.7 cm	49.5 in.

Conveyor System

Horizontal Auger Diameter	25.4 cm	10 in.
Vertical Auger Diameter	25.4 cm	10 in.

Manueverability

Wheelbase	1.96 m	77 in.
Wheel Track	1.37 m	54 in.
Turning Radius at Conditioner	4.87 m	16 ft.

Weight

Empty with Lead Acid Battery	4423 kg	9750 lb
with Water with Lead Acid Battery	5148 kg	11350 lb



Advanced Water System — AWS™

Regulates amount of water dispensed onto the ice relative to machine speed for efficient and even application. *optional equipment



Zamboni Power Brush™

Wider brush path reaches higher on the dasher board kick plate for superior cleaning power. *optional equipment



Integrated Auger Washout System

Simplifies the vertical and horizontal auger washout task, from a single point on the conditioner. *optional equipment

MODEL
552 **AC**
ELECTRIC

STANDARD FEATURES

2 Year Warranty
400 Micron Wash Water Deep Filter Bag
Aluminum Alloy Wheels
Battery Charger: Microprocessor Controlled
Brushless AC Motors
Chassis: Strong All Welded Steel Tubing
Conditioner Safety Guards
Dependable Sevcon® Gen4 Solid State Controls
Digital Training and Reference Materials
Familiar Automobile-Style Foot Controls
Four-Wheel Drive
Guide Wheel
Headlights and Tail Light (for Off Ice Travel)
High Quality 9 Micron Filter
High Speed Vertical Auger
Hydraulic Oil Level Sight Gauge
Industry-Proven Lead Acid Batteries
On-Dash Diagnostics

Parking Brake
Power Steering
Premium Polyester Felt Spreader Towel
Replaceable Poly Conditioner Side Plates
Rugged Dana Spicer® Axles
Rust-Free Poly Ice Making Water Tank
Snow Tank Safety Stand
Spare Tire and Wheel
Stainless Steel Hardware
Steering Wheel Spinner Knob
Touch Up Paint Kit
Tungsten Carbide Studded Tires
Variable Speed Electric Hydraulic Pump Motor
Wide Spectrum of Premium Automotive Paint Colors

OPTIONS

Advanced Water System (AWS™)
Automatic Snow Breaker
Back Up Alarm
Battery Watering Gun
Battery Watering System
[Blade Change System](#)
Cab Enclosure
Conditioner: 96" Blade
Conditioner: Galvanized
Electric Water Level Gauge
[FastICE® Ice Making System](#)
IceCaps® Wheel Advertising System
Integrated Auger Washout System
[Level-Ice™](#)
Low Guide Wheel
Seat Belt
Snow Melting Kit
Snow Tank Dump Height Restriction
Snow Tank Light

Stainless Steel Water Distribution Pipe
Tire Wash System
Wash Water to Ice Making Water Transfer
Wash Water System with Poly Tank
Water Level Sight Gauge
Zamboni Power Brush™ Board Brush System
[Zamboni Connect™ System](#)

ZAMBONI®

Some features described or shown may be optional at extra cost and prices, colors, materials, specifications and models are subject to change. Some options are required in combination with other options. ZAMBONI and the configuration of the Zamboni® ice resurfacing machine are registered trademarks of Frank J. Zamboni & Co., Inc. © Zamboni 2021

Rev 03/2021