

MODEL 450

LITHIUM-ION

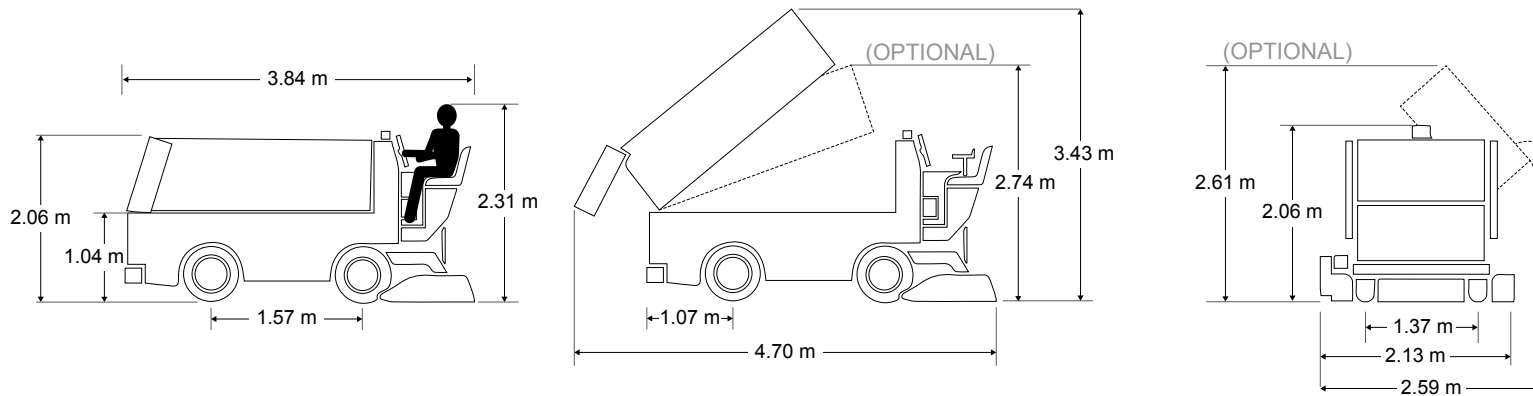

CAPACITIES

Snow Tank

Actual Volume	2.66 m ³	94 cu. ft.
Compacted	3.17 m ³	112 cu. ft.

Water

Ice Making	627 L	166 gal.
Wash Water	218 L	58 gal.
Total	845 L	224 gal.

Hydraulic Oil

	72 L	19 gal.
--	------	---------

POWERTRAIN

Four-Wheel Drive

Battery 96V , 210 Ah (21.5kWh) Lithium-ion (Li)

Transmission Continuously variable hydrostatic pump and motor are axial-piston type.

Hydraulics Powerful single pump for the vertical and horizontal augers. Hydraulic down pressure for optimal resurfacing results.

Axles

Front	1950 kg	4300 lb
Rear	2177 kg	4800 lb

Brakes Full Hydrodynamic Braking with Rear Drum Brakes

DIMENSIONS

Overall

	L	W	H	L	W	H
Snow Tank Down	3.84 m	2.13 m	2.06 m	151 in.	84 in.	81 in.
Snow Tank Up	4.70 m	2.13 m	3.43 m	185 in.	84 in.	135 in.

Shaving Blade

	L	W	H	L	W	H
	195.6 cm	12.7 cm	1.27 cm	77 in.	5 in.	0.5 in.

Clearance

Minimum Operator Height Clearance		2.31 m	91 in.
Snow Pit Clearance		104.1 cm	41 in.

Conveyor System

Horizontal Auger Diameter	25.4 cm	10 in.
Vertical Auger Diameter	25.4 cm	10 in.

Manueverability

Wheelbase	1.57 m	62 in.
Wheel Track	1.37 m	54 in.
Turning Radius at Conditioner	4.57 m	15 ft.

Weight

Empty	2660 kg	5860 lb
with Water	3502 kg	7720 lb



Automatic Snow Breaker

Eliminates the need for manual control of the snow breaker by the machine operator.

*optional equipment



Integrated Auger Washout System

Simplifies the vertical and horizontal auger washout task, from a single point on the conditioner.

*optional equipment



Ergonomic Seat

Designed with the operator in mind, our premium seat has optimal adjustability.

*optional equipment



STANDARD FEATURES

- 2 Year Warranty
- 400 Micron Wash Water Deep Filter Bag
- Aluminum Alloy Wheels
- Chassis: Strong All Welded Steel Tubing
- Conditioner Safety Guards
- Digital Training and Reference Materials
- Familiar Automobile-Style Foot Controls
- Four-Wheel Drive
- Full Hydrodynamic Braking
- Guide Wheel
- Headlights and Tail Light (for Off Ice Travel)
- High Quality 10 and 25 Micron Filters
- High Speed Vertical Auger
- Hydraulic Oil Level Sight Gauge
- Load Sensing Motor Governor
- Motor: High Efficiency Permanent Magnet AC
- Motor Control: Sevcon Motor Control
- On-Dash Diagnostics
- Parking Brake
- Power Steering
- Premium Polyester Felt Spreader Towel
- Replaceable Poly Conditioner Side Plates
- Rugged Dana Spicer® Axles
- Snow Tank Safety Stand
- Spare Tire and Wheel
- Steering Wheel Spinner Knob
- Touch-Up Paint Kit
- Tungsten Carbide Studded Tires
- Under Seat Storage
- Wide Spectrum of Premium Automotive Paint Colors

OPTIONS

- Automatic Snow Breaker
- Back Up Alarm
- Battery and Motor Diagnostic Computer Interface Tool
- [Blade Change System](#)
- Conditioner: Galvanized
- Electric Water Level Gauge
- Fire Extinguisher
- Heated Ergonomic Comfort Design Seat
 - Armrest
 - Seatbelt
- IceCaps® Wheel Advertising System
- Integrated Auger Washout System
- [Level-Ice™](#)
- Rotating Beacon Light
- Side Snow Tank Dump
- Snow Melting Kit
- Snow Tank Dump Height Restriction
- Snow Tank Light
- Snow Tank Non-Stick Liner
- Stainless Steel Water Distribution Pipe
- Tire Wash System
- Wash Water to Ice Making Water Transfer
- Water Level Sight Gauge
- [Zamboni Connect™ System](#)
- Zamboni Power Board Brush™ System