

MODEL 450

LITHIUM-ION

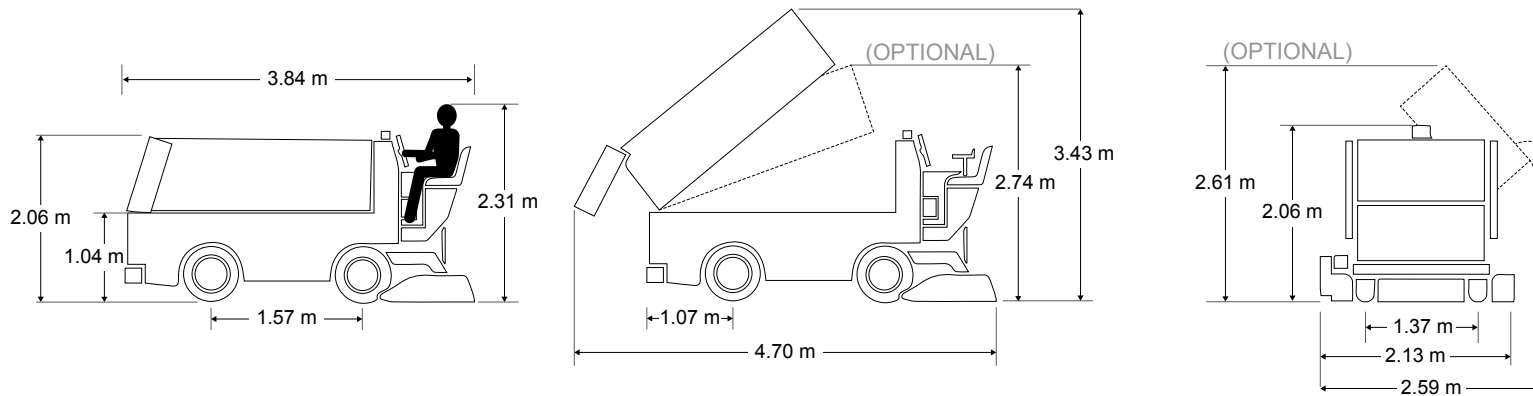

CAPACITIES

Snow Tank

Actual Volume	2.66 m ³	94 cu. ft.
Compacted	3.17 m ³	112 cu. ft.

Water

Ice Making	627 L	166 gal.
Wash Water	218 L	58 gal.
Total	845 L	224 gal.

Hydraulic Oil	72 L	19 gal.
----------------------	------	---------

POWERTRAIN

Four-Wheel Drive

Battery Safe, High Power Density Lithium Iron Magnesium Phosphate (LiFeMgPO₄) Batteries.

Transmission Continuously variable hydrostatic pump and motor are axial-piston type.

Hydraulics Powerful single pump for the vertical and horizontal augers. Hydraulic down pressure for optimal resurfacing results.

Axles

Front	1950 kg	4300 lb
Rear	2177 kg	4800 lb

Brakes Full Hydrodynamic Braking with Rear Drum Brakes

DIMENSIONS

Overall

	L	W	H	L	W	H
Snow Tank Down	3.84 m	2.13 m	2.06 m	151 in.	84 in.	81 in.
Snow Tank Up	4.70 m	2.13 m	3.43 m	185 in.	84 in.	135 in.

Shaving Blade

	L	W	H	L	W	H
	195.6 cm	12.7 cm	1.27 cm	77 in.	5 in.	0.5 in.

Clearance

Minimum Operator Height Clearance	2.31 m	91 in.
Snow Pit Clearance	104.1 cm	41 in.

Conveyor System

Horizontal Auger Diameter	25.4 cm	10 in.
Vertical Auger Diameter	25.4 cm	10 in.

Manueverability

Wheelbase	1.57 m	62 in.
Wheel Track	1.37 m	54 in.
Turning Radius at Conditioner	4.57 m	15 ft.

Weight

Empty	2660 kg	5860 lb
with Water	3502 kg	7720 lb