

Capacities/Dimensions

Snow Tank

Actual Volume	2.83 m ³	(100 cu. ft.)
Compacted	3.54 m ³	(125 cu. ft.)
Excess Water	416 L	(110 USG, 92 IMP)

Water

Ice Making	727 L	(192 USG, 160 IMP)
Wash Water	273 L	(72 USG, 60 IMP)
Total	1000 L	(264 USG, 220 IMP)

Hydraulic Oil	95 L	(25 USG, 21 IMP)
---------------	------	-------------------

Conveyor System

Horizontal Auger	25.4 cm (10 in.) dia.
Vertical Auger	25.4 cm (10 in.) dia.

Overall Length

Snow Tank Down	4.04 m (159 in.)
Snow Tank Up	5.03 m (198 in.)

Overall Height

Snow Tank Down	2.20 m (87 in.)
Snow Tank Up	3.91 m (154 in.)

Overall Width	2.13 m (84 in.)
---------------	------------------

Wheelbase	1.95 m (77 in.)
-----------	------------------

Wheel Track	1.37 m (54 in.)
-------------	------------------

Turning Radius

At Conditioner	4.86 m (16 ft.)
----------------	------------------

Shaving Blade	1.27 x 12.7 x 195.6 cm 1/2" x 5" x 77"
---------------	---

Vehicle Weight

Empty	3143 kg (6930 lb.)
w/Water	4240 kg (9530 lb.)

Engine Specifications/Features

Ford 2.5 litre.

Four cylinder overhead valve, liquid cooled, hydraulic lifters.

63 HP @2800 RPM NET.

Powerful and efficient.

Load sensing electronic governor enables true "hands-free" operation by driver.

520

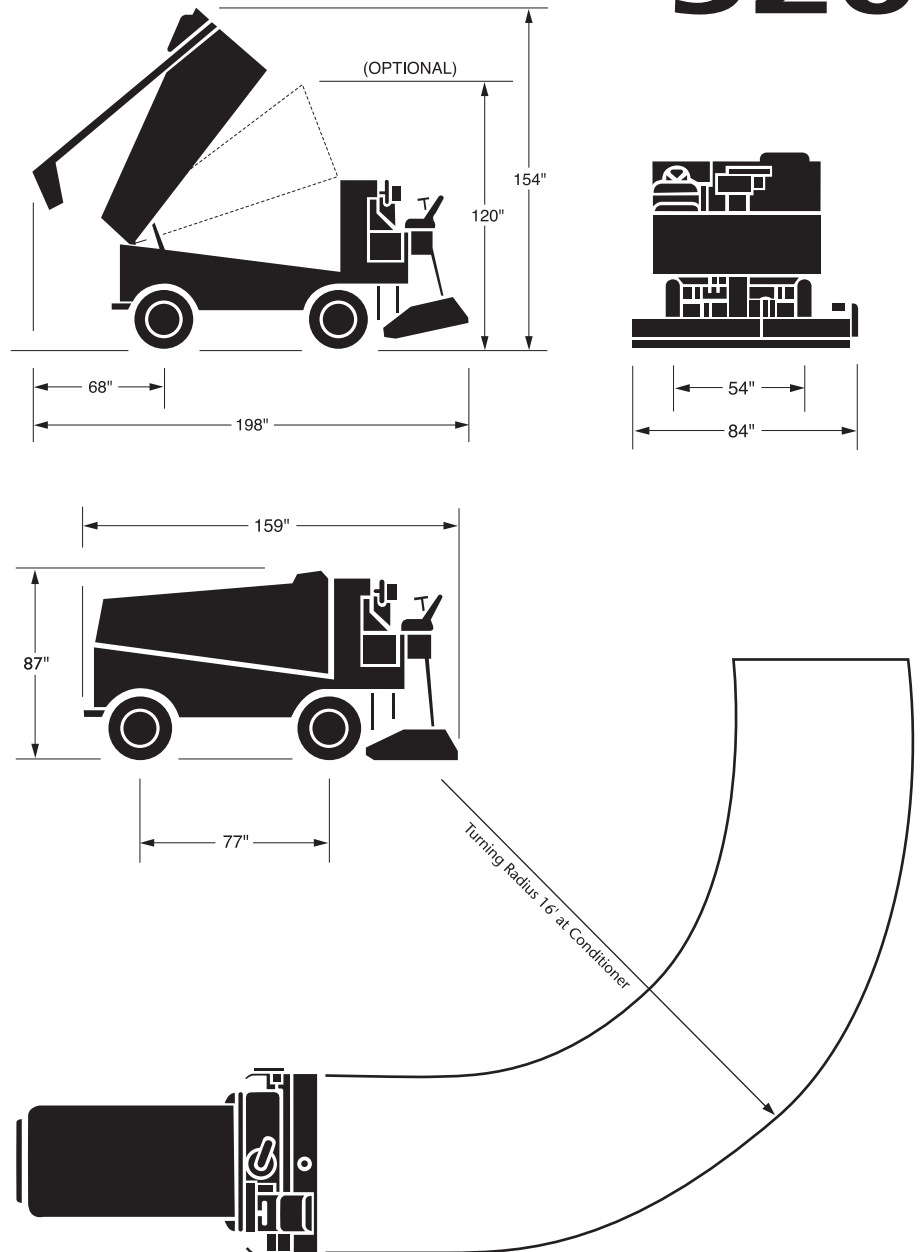

This brochure has been prepared only as a general guide to the customer. Every effort has been made to insure that all information is correct at the time of printing. Zamboni reserves the right to change prices, colors, materials, specifications and models. Some features described, or shown, may be optional at extra cost. Some options are required in combination with other options. Zamboni and the configuration of the Zamboni® ice resurfacing machine are registered trademarks of Frank J. Zamboni & Co., Inc.

ZAMBONI®

Zamboni USA

Frank J. Zamboni & Co., Inc.
15714 Colorado Ave., Paramount, CA USA 90723-4211
Phone (562) 633-0751 Fax (562) 633-9365

Zamboni Canada

Zamboni Company Ltd.
38 Morton Ave. East, Box 1388, Brantford, ON Canada N3T 5T6
Phone (519) 758-5000 Fax (519) 758-0500

Zamboni Europe

Eigentalsstrasse 1, Box 123, CH-8309 Nuerensdorf, Switzerland
Phone +41 44 837 01 91 Fax +41 44 837 01 80

www.zamboni.com

