

# 440

## Capacities/Dimensions

### Snow Tank

Actual Volume	2.66 m <sup>3</sup> ( 94 cu. ft.)
Compacted	3.17 m <sup>3</sup> (112 cu. ft.)

### Water

Ice Making	627 L (166 USG, 138 IMP)
Wash Water (opt.)	218 L ( 58 USG, 48 IMP)
Total	845 L (224 USG, 186 IMP)

Hydraulic Oil	72 L ( 19 USG, 16 IMP)
---------------	------------------------

### Conveyor System

Horizontal Auger	25.4 cm ( 10 in.) dia.
Vertical Auger	25.4 cm ( 10 in.) dia.

### Overall Length

Snow Tank Down	3.84 m (151 in.)
Snow Tank Up	4.70 m (185 in.)

### Overall Height

Snow Tank Down	2.06 m ( 81 in.)
Snow Tank Up	3.43 m (135 in.)

Overall Width	2.13 m ( 84 in.)
---------------	------------------

Wheelbase	1.57 m ( 62 in.)
-----------	------------------

Wheel Track	1.37 m ( 54 in.)
-------------	------------------

### Turning Radius

At Conditioner	4.57 m ( 15 ft.)
----------------	------------------

Shaving Blade	1.27 x 12.7 x 195.6 cm 1/2" x 5" x 77"
---------------	---

### Vehicle Weight

Empty	2660 kg (5860 lb.)
w/Water	3285 kg (7240 lb.)

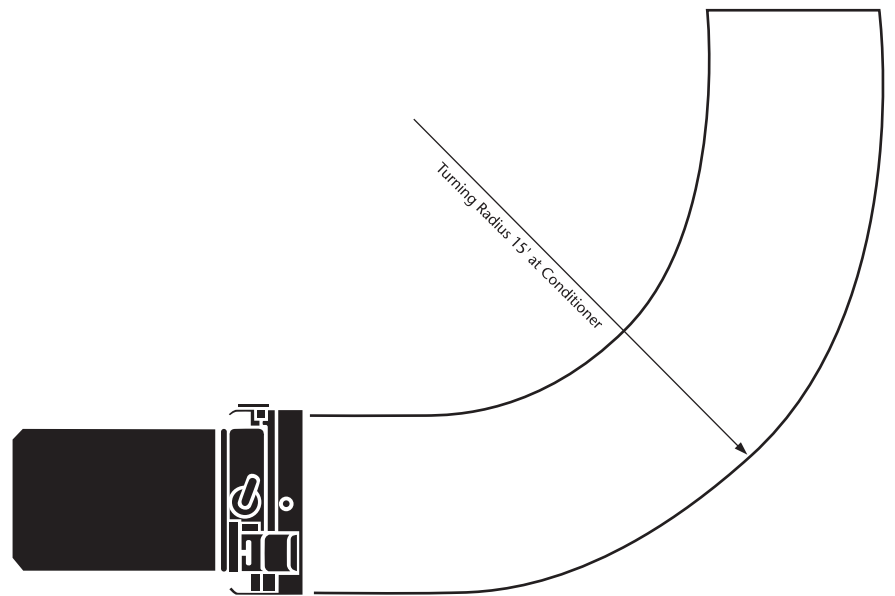
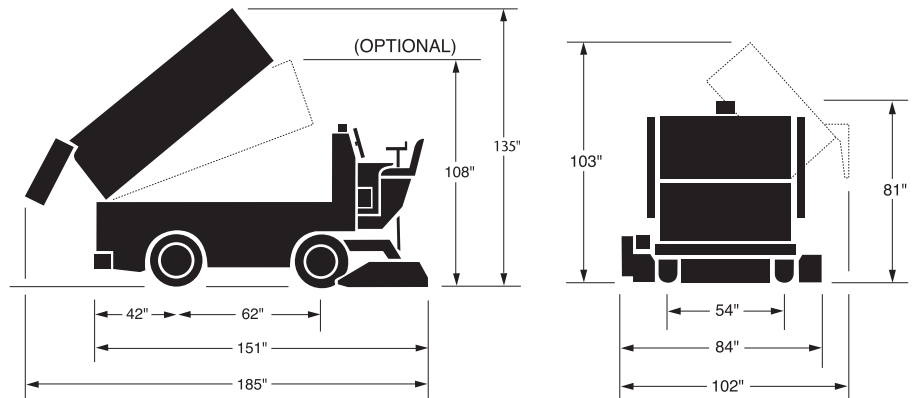

## Engine Specifications/Features

Ford 2.5 litre.

Four cylinder overhead valve, liquid cooled, hydraulic lifters.

63 HP @2800 RPM NET.

Powerful and efficient.

Load sensing electronic governor enables true "hands-free" operation by driver.

This brochure has been prepared only as a general guide to the customer. Every effort has been made to insure that all information is correct at the time of printing. Zamboni reserves the right to change prices, colors, materials, specifications and models. Some features described, or shown, may be optional at extra cost. Some options are required in combination with other options. Zamboni and the configuration of the Zamboni® ice resurfacing machine are registered trademarks of Frank J. Zamboni & Co., Inc.

# ZAMBONI®

### Zamboni USA

Frank J. Zamboni & Co., Inc.  
15714 Colorado Ave., Paramount, CA USA 90723-4211  
Phone (562) 633-0751 Fax (562) 633-9365

### Zamboni Canada

Zamboni Company Ltd.  
38 Morton Ave. East, Box 1388, Brantford, ON Canada N3T 5T6  
Phone (519) 758-5000 Fax (519) 758-0500

### Zamboni Europe

Eigentalsstrasse 1, Box 123, CH-8309 Nuerensdorf, Switzerland  
Phone +41 44 837 01 91 Fax +41 44 837 01 80

[www.zamboni.com](http://www.zamboni.com)

