

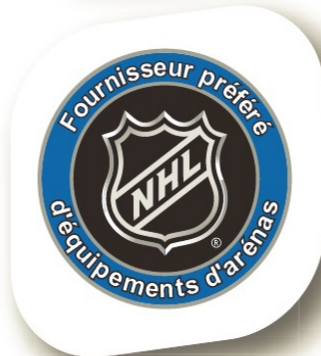

Robert Boileau inc.



Catalogue online at
arenazone.com

1425, boul. Pitfield, Saint-Laurent QC H4S 1G3
Tél. : (514) 333-8420 Fax : (514) 333-7056
Toll free : 1 877 333-8420
Membre: AQAIRS, APOM, AQLM and ORFA

BRANCH IN QUEBEC CITY FOR EAST QUEBEC

Table of content

The essentials	3
Towel	3
Squeegee	3
Board brush	3
Neutral switch	3
Cable and Pulley	3
Blade Angle Adjustment	3
Paddle with metal insert for TMA-200	3
Parts for conditioner	4
Blades	4
Blade angle adjustment gauge	4
Lateral Conditioner Runner Protector.	4
Knife guard	4
Conti Blade-Changing Assistant	5
Tires and studs	6
Hydraulic	7
Augers and bearings	7
Snow braker	7
The outside of the ice resurfacer	8
Bumper Guide Wheel	8
Head light	8
Replacement parts for water pump	9
Pump impeller and more	9
Batteries and cables	10
Propane Accessories	11
Water tank	11
Edgers and parts	12
DYNASCRUB Board Scrubber	13
Green Diamond Charger	14
Fuelmaker Compressor	15
Level Ice (Laser Leveling System)	16

THE ESSENTIALS

For true performance, ask for
ZAMBONI
 Genuine parts
 EXCLUSIVE DISTRIBUTOR

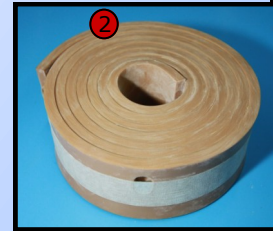
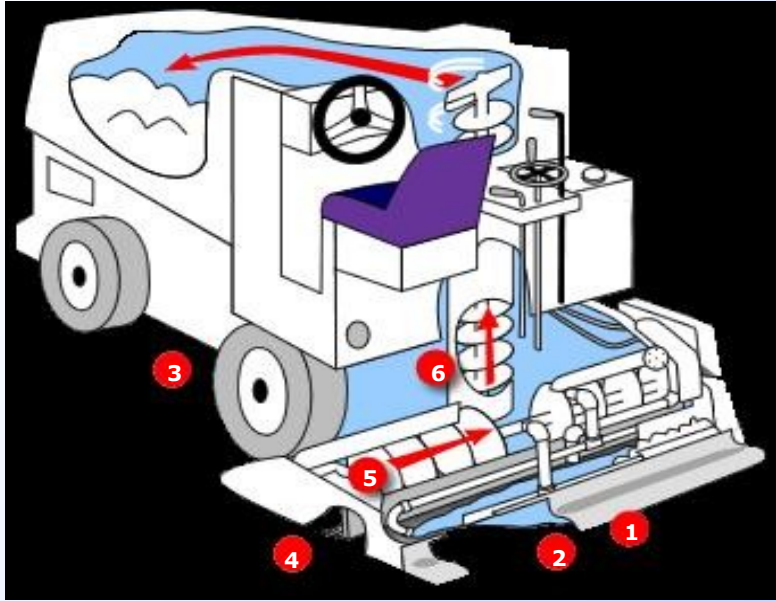

- 1- 77" TOWEL
 ⇒ WHITE **5P-33620**
 ⇒ BLACK **5P-33630**
- 2- 77" SQUEEGEE
 ⇒ **5M-33550**
- 3- BOARD BRUSH
 ⇒ SINGLE **5V-62020**
 ⇒ DOUBLE **KZ-62020**
- WHITE SPREADER CLOTH, SQUEEGEE AND BRUSH KIT
 ⇒ **KZ-33650**
 BLACK SPREADER CLOTH, SQUEEGEE AND BRUSH KIT
 ⇒ **KZ-33660**



Neutral switch
 ⇒ **7P-79621**



ALSO AVAILABLE UPON REQUEST:
 Olympia towels, brushes and blades.



Cable et pulley
 ⇒ **33-40335 (cable & clamp)**
 ⇒ **41-42000 (pulley & bushing)**

Paddle with metal insert for TMA-200
 ⇒ **00-00458**



To purchase Zamboni parts, Call André Soucy
 514-333-8420 ext. 2 or toll free 1-877-333-8420
pieces@arenazone.com

REPLACEMENT PARTS FOR CONDITONER



Kit of 10 stainless stell blade bolts, washers and nuts

⇒ **00-00174SK**

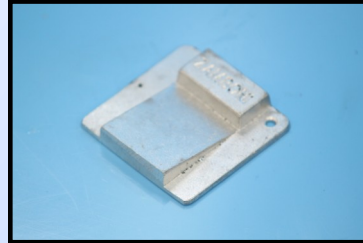

Blade angle adjustment gauge

⇒ **84-01100**

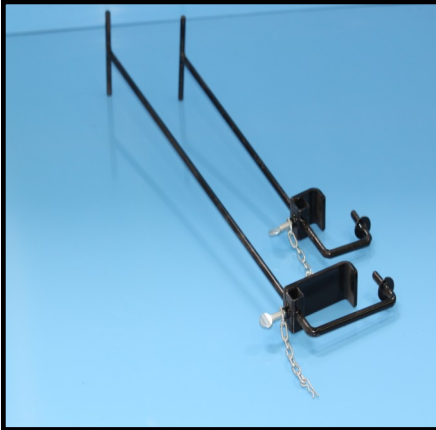

Hooks for conditioner. For an easy installation of the blade.

⇒ **5K-1207C**

ZAMBONI BLADE CONDITONNER
77" X 5"
ROCKWELL 61/63

THESE BLADES ARE MADE OF A SUPERIOR ALLOY HARDNESS THAT EXTENDS THE QUALITY OF CUT AND REDUCES THE FREQUENCY OF SHARPENING.

⇒ **5K-33630**

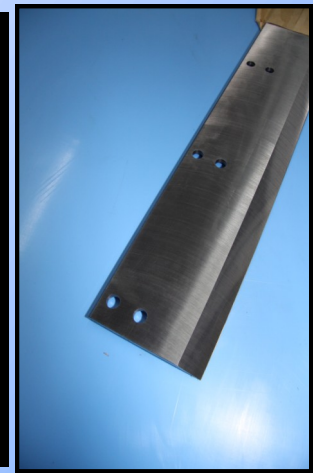

Knife guard

⇒ **5H-0501A**

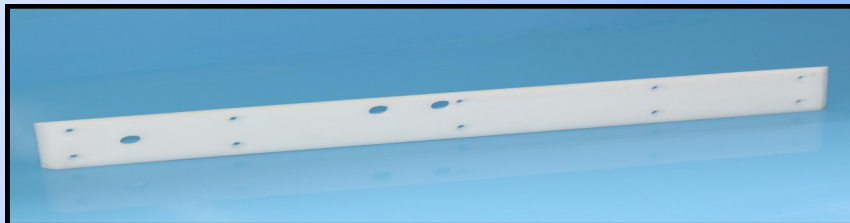

Lateral conditioner runner protector

⇒ **5H-0501A**

To purchase Zamboni parts, Call André Soucy
514-333-8420 ext. 2 or toll free 1-877-333-8420

pieces@arenazone.com

CONTI

BLADE-CHANGING-ASSISTANT

www.conti-edger.com/Conti-Assistant.html

Change your ice-resurfacers blade:

For a demo-video, go to www.youtube.com/user/ContiAssistant

- **Without** having to reach under the conditioner
- **without** having to kneel down on the floor
- & even **without** having to touch the blade at all

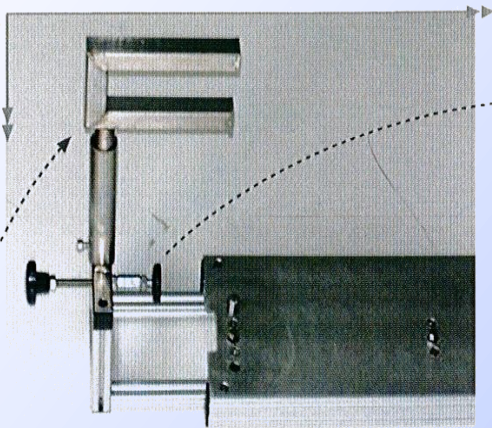

With the turnable **Telescop Handles** the Blade-Changing-Assistant will be raised & clamped to the ice-resurfacer's conditioner

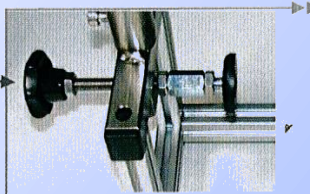

For easy positioning, the correct distance to the conditioner can be fixed by help of the **Adjustment Button ...**

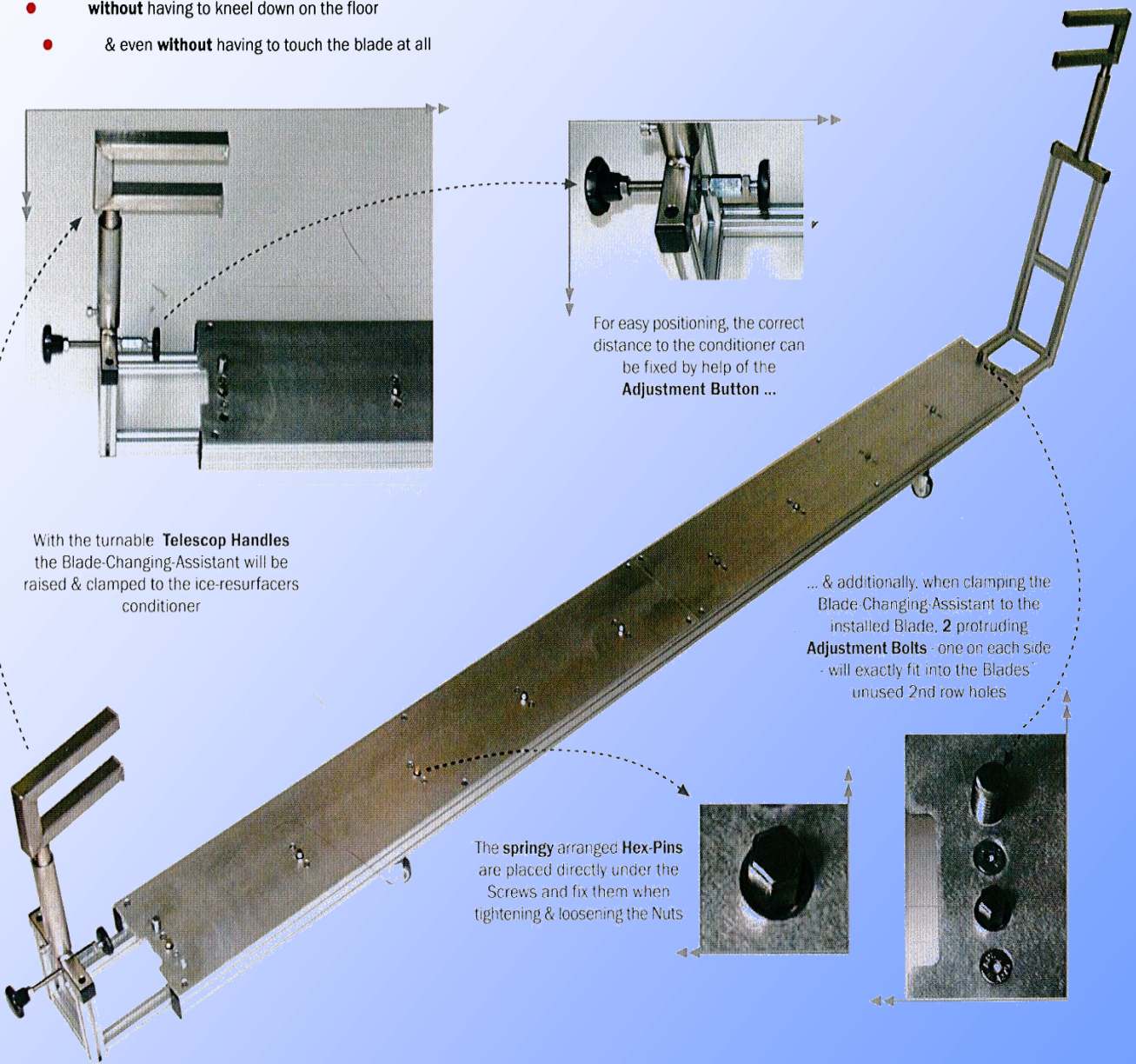

... & additionally, when clamping the Blade-Changing-Assistant to the installed Blade, **2 protruding Adjustment Bolts** - one on each side - will exactly fit into the Blades' unused 2nd row holes

The **springy arranged Hex-Pins** are placed directly under the Screws and fix them when tightening & loosening the Nuts



77'' for Zamboni blade
⇒ 5K-34000

84'' for Olympia blade
⇒ 5K-34100

TIRES AND STUDS



ITEM	DESCRIPTION	DIMENSION	ZAMBONI
1B-0700D	STUDED TIRE 552 BAHA LUG TYPE	LT245/75R16	552 ET 560
1B-51722	ZAMBONI RADIAL STUDED TIRE	LT215/85R16	520 ET 525
1B-0440A	ZAMBONI RADIAL STUDED TIRE	LT215/75R15	440 ET 445

Other sizes available upon request.
Rim are also available.

Tire studs

For all Zamboni
⇒ **1B-10000**



To purchase Zamboni parts,
Call André Soucy
514-333-8420 ext. 2
Toll free 1-877-333-8420

pieces@arenazone.com

REPLACEMENT PARTS FOR HYDRAULIC

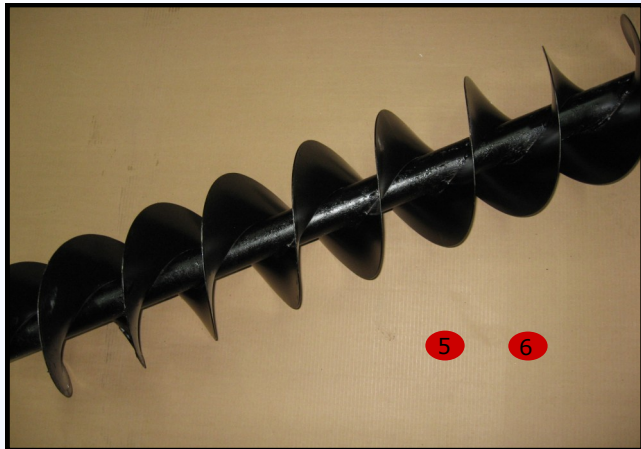

5- HORIZONTAL AUGER
 ⇒ **SPIRALEH (refurbished)**

6- VERTICALE AUGER
 ⇒ **SPIRALEV (refurbished)**

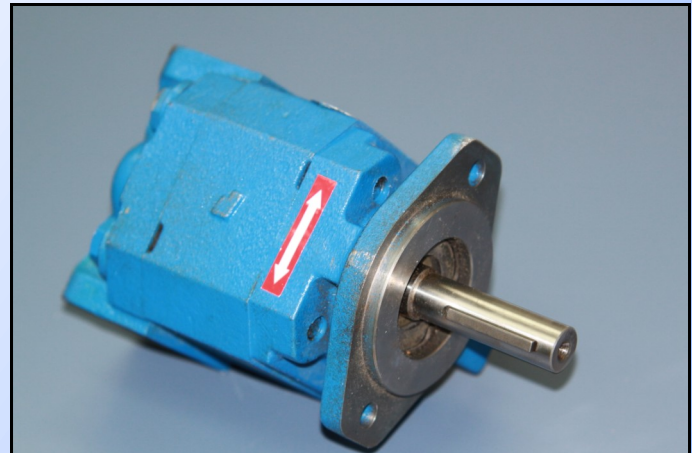

Gear Motor
 ⇒ **2M-74530**

Snow braker
 ⇒ **5C-69630**



Bearing for horizontal and vertical auger



Fit all models except 552 et 560

⇒ **1X-33490 (horizontal)**

⇒ **1X-36642 (vertical)**



For models 552 et 560

⇒ **1X-33490P (horizontal)**

⇒ **1X-36642P (vertical)**

To purchase Zamboni parts, Call André Soucy
 514-333-8420 ext. 2 or toll free 1-877-333-8420

pieces@arenazone.com

THE OUTSIDE OF THE ICE RESURFACER

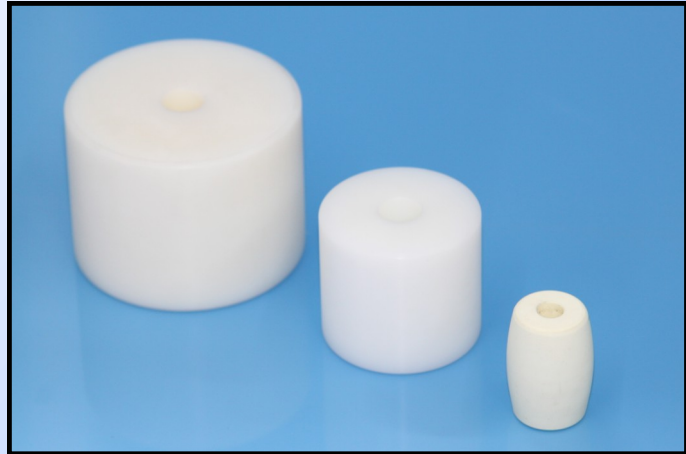

Guide Wheel

- Zamboni 440 et 445
⇒ **8R-04410**
- Zamboni 520 , 525, 552 et 560
⇒ **8R-16800**

Roller board

⇒ **8R-0500B**



OPTIONAL
Bumper with lower
guide wheel

⇒ 8T-15900



HEADLIGHT

Zamboni	Incandescents	Halogenes
400-440	7L-04011	
445		7L-04022
520-552*	7L-17970	
525-552-560		7L-17980
* halogene headlight for serial number higher than 9362		

To purchase Zamboni parts,
Call André Soucy
514-333-8420 ext. 2
Toll free 1-877-333-8420

pieces@arenazone.com

REPLACEMENT PARTS FOR WATER PUMP

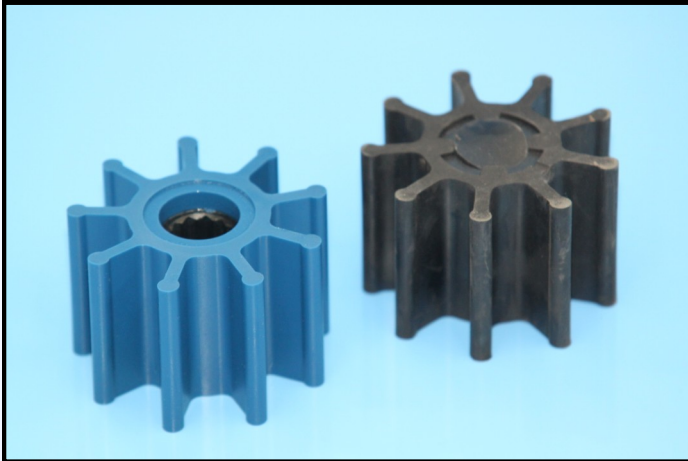

Pump impeller

- Black, neoprene
⇒ **2P-33850**

For endurance and durability

- **Blue impeller**
⇒ **2P-33852**



1-1/4" Water control valve

⇒ **2V-79700**



Wash water pump

⇒ **2P-37570**



Hydraulic cylinders that meet Zamboni's specifications

**To purchase Zamboni parts,
Call André Soucy
514-333-8420 ext. 2
Toll free 1-877-333-8420**

pieces@arenazone.com

BATTERIES AND CABLES



Batteries and cables
⇒ Batteries 552



Automatic watering system
for batteries

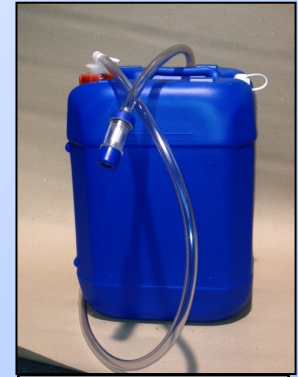

Filling kit 20 litres
(Kit BFS)



Battery cap for 552
⇒ **BFSB**

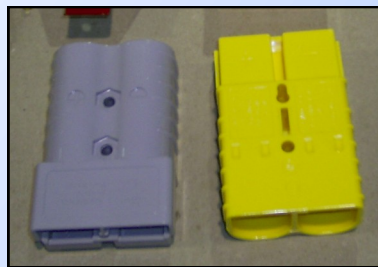

Yellow or grey connector



Water level monitor

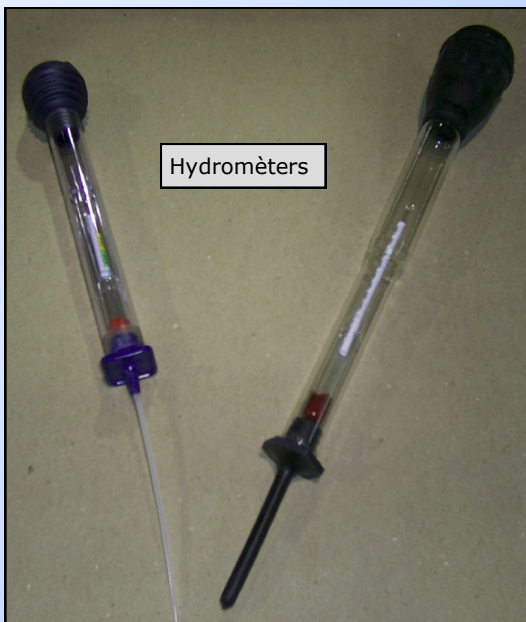

Hydrometers



Deionisation
system
PS300

Replacement
filter
PS600



Neutralizer
⇒ **SDN1**

BFS Connector male => **CM**
BFS Connector female => **CF**



To purchase Zamboni parts, Call André Soucy
514-333-8420 ext. 2 or toll free 1-877-333-8420

pieces@arenazone.com

Propane accessories



Propane coupler
 ⇒ **FW-3901F**

Hose
 3/8" x 150"
 ⇒ **P4-3600B**

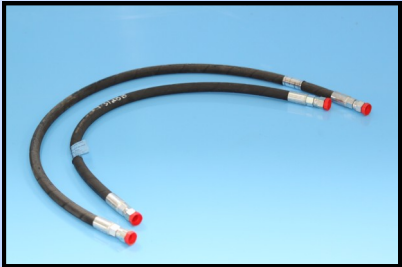

Hose
 ⇒ **P4-3128B** 3/8" x 32"
 ⇒ **P4-3176B** 3/8" x 44"

Water tank

Zamboni polyethylene tank

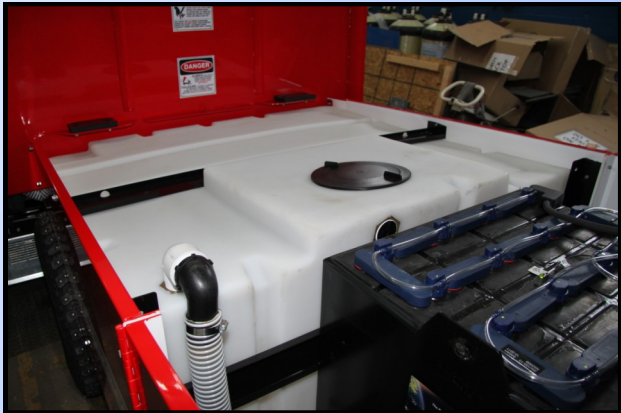

**NEW AND REBUILT CONDITIONERS
 AVAILABLE**

**CORE SERVICE FOR
 POLYETHYLENE TANK**

**To purchase Zamboni parts, Call André Soucy
 514-333-8420 ext. 2 or toll free 1-877-333-8420**

pieces@arenazone.com

THE EDGERS AND THEIR PARTS



ZAMBONI ELECTRIC
POWERED EDGER
5E-4000



ZAMBONI 10.5 hp
Gaz powered edger

- Edger Model:**
- 5E-4000**
EZ-III electric,
Battery powered edger
 - 5E-10500**
10.5 hp Gaz powered edger
with wrope starter
 - 5E-10510**
10.5 hp Gaz powered edger
with electric starter
 - 5E-10520**
10.5 hp Propane powered
edger with electric starter

Replacement blades:

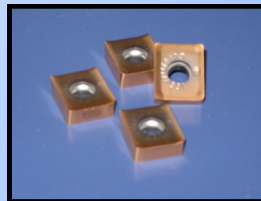
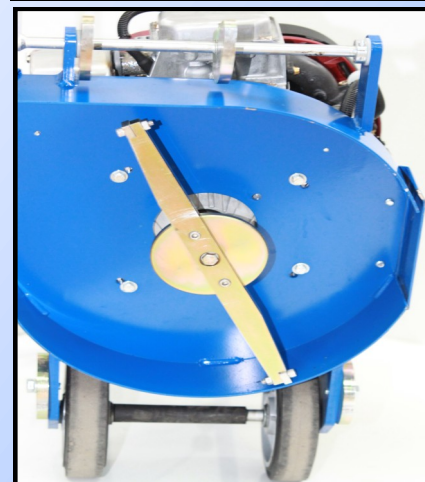

Eliz 300 (Set of 4)
⇒ **5K-30000**

Eliz 336 (Set of 6)
⇒ **5K-30006**

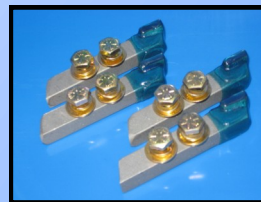

Honda (Set of 4)
⇒ **00-06091**

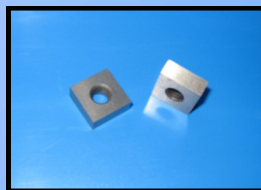

For gaz and propane Zamboni edger
⇒ **5K-83522** (set of 2)

Electric Zamboni edger requires 4 kits
⇒ **5K-83522** (x4)

Battery charger
24V => 79-30000
36V => 79-33605



DYNASCRUB

**AVAILABLE
UPON
REQUEST**



Board scubber

HYDRAULICALLY DRIVEN FROM EXISTING HYDROLIC SYSTEM.

⇒ **X600-087**

Cleaning product also available.

**To purchase Zamboni parts,
Call André Soucy
514-333-8420 ext. 2
Toll free 1-877-333-8420**

pieces@arenazone.com



2 sets of quick couplers required
⇒ **PS 1/2F**

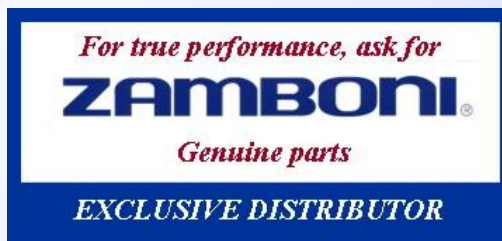

Green Diamond Charger for Zamboni 552 et 560

⇒ **CHAR-GREEN552**

Gaining wide popularity with dealers and users alike, this charger has the versatility to be used for standard charging and "Opportunity" charging. The microprocessor control utilizes the "Pulse Mix System" to ensure excellent battery care.



This system offers a very high electrical efficiency, near unity power factor and very low output current ripple. This is done through a 'passive' conversion process of AC input to DC output.

The Opportunity charging mode allows the user to reduce the finish cycles to once a week if desired. This keeps the battery in the "sweet spot" of charge where the battery has many hours of operations but avoids heat that comes with finishing.

Our exclusive PulseMix system ensures a gentle finish on the battery. This limits over-charge, over-gassing and extra-heat to the battery while applying controlled high current to effectively stir the electrolyte.

A Real-Time Clock is standard and allows:

- o Desired start time
- o Finish charge window
- o Scheduled weekly Equalize time

Green Diamond can monitor:

- o Total Energy Saved (KWh)
- o Total Reduction of Greenhouse Gas Emission (lbs. of CO₂)
- o Total Savings on Energy Bill (USD\$)

Fleet Management System adder opens eyes:

- o DoctorFleet.com is a WEB based interface
- o Retrieval of real time and historic data
- o Emailed alerts and usage reports

**To purchase Zamboni parts,
Call André Soucy
514-333-8420 ext. 2
Toll free 1-877-333-8420**

pieces@arenazone.com

For true performance, ask for
ZAMBONI[®]
 Genuine parts
 EXCLUSIVE DISTRIBUTOR



**FuelMaker
 System
 for natural gas**

Electronic board PR 770402 S

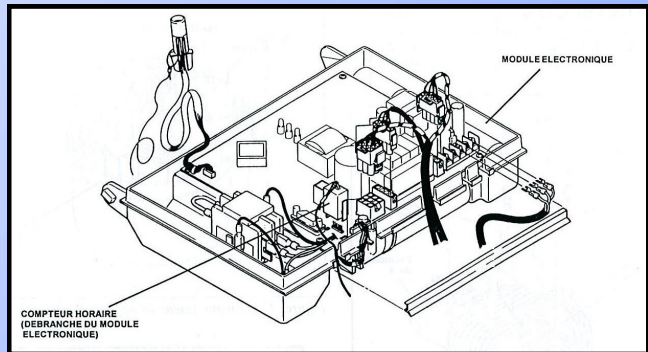

Filling hose (non-illustrated) H4.5FP30

- 1- Compressor
- 2- Control unit

- PR 770313 S
- PR 770113 S

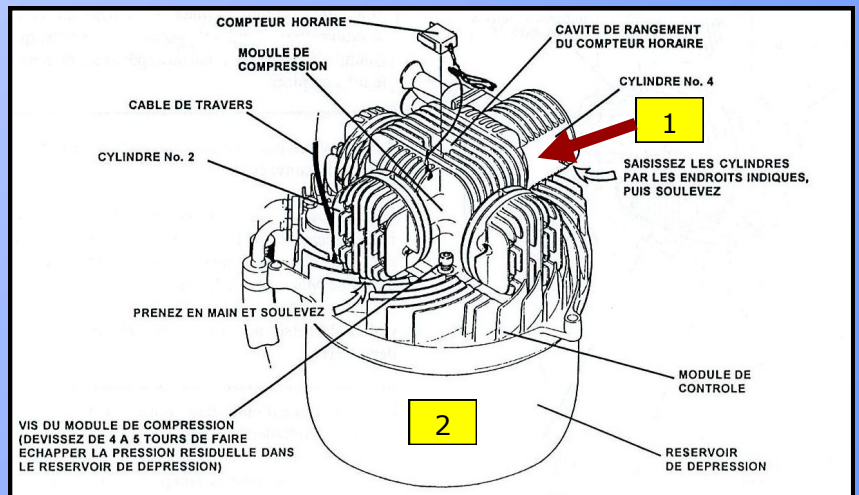
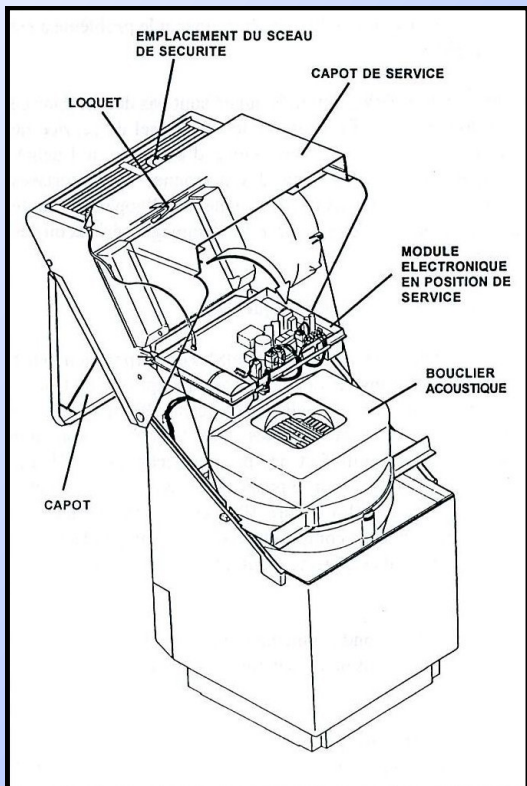



Level-Ice™

Skaters will love the hard, level ice surface

Simple to install. Simple to use.

Lets the operator focus on driving.

The Level-Ice Laser Leveling System will automatically control the cutting blade of the conditioner to achieve an accurate, level ice surface. The system can be installed on all ice resurfacing machines.

Level-Ice will:

- Provide consistent level ice
- Reduce resurfacing cut to save paint lines
- Reduce wear and tear on your ice resurfacer
- Reduce amount of snow
- Eliminate operator error
- Reduce operating costs
- Reduce energy usage
- Reduce amount of flood water use
- Reduce run time on your compressor
- Extend blade life by approximately 50%
- Reduce maintenance time
- Free up ice time for rental

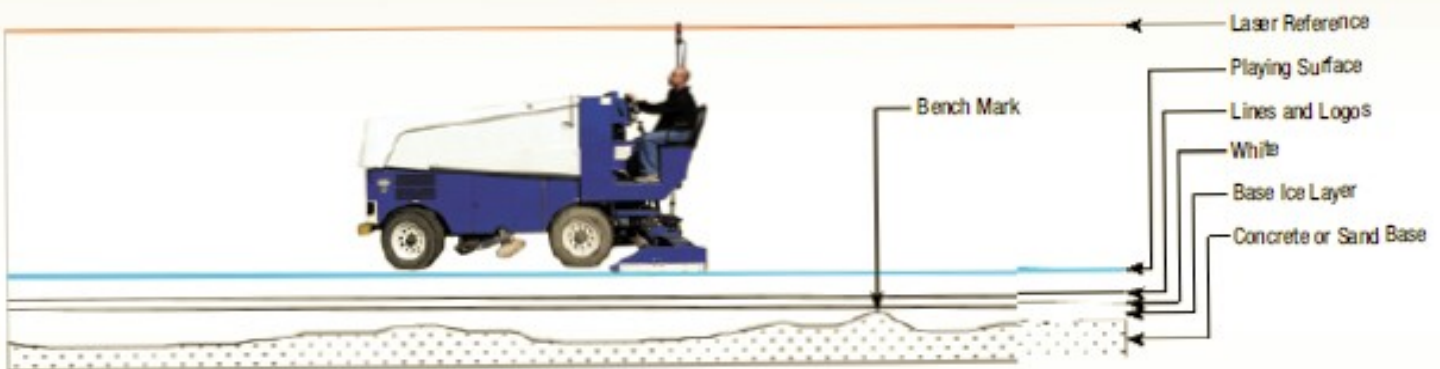

Level-Ice literally takes all the guess work out of producing a perfectly level sheet of ice. The laser controlled ice leveling system provides accurate reference point to within .5 mm. Using the most advanced receiver technology, the system controls the cutting blade of the conditioner to give your ice a perfectly level surface after every flood.

EXCLUSIVE AT



Level Ice. Every time.